











Theory and Repair of Astron Linear Power Supplies

George K1IG

Topics

-  **Linear Power Supplies**
-  **Astron Observations**
-  **Block Diagrams**
-  **Components**
-  **Electrical Safety**
-  **Troubleshooting & Repair**
-  **Test & Calibration**
-  **Efficiency & Noise Measurements**

Linear Power Supplies

- Convert AC to DC and maintain steady voltage with a linear regulator
- The regulator acts as a variable resistor in a voltage divider circuit
- The linear regulator varies its resistance in accordance with the load to maintain a constant output voltage

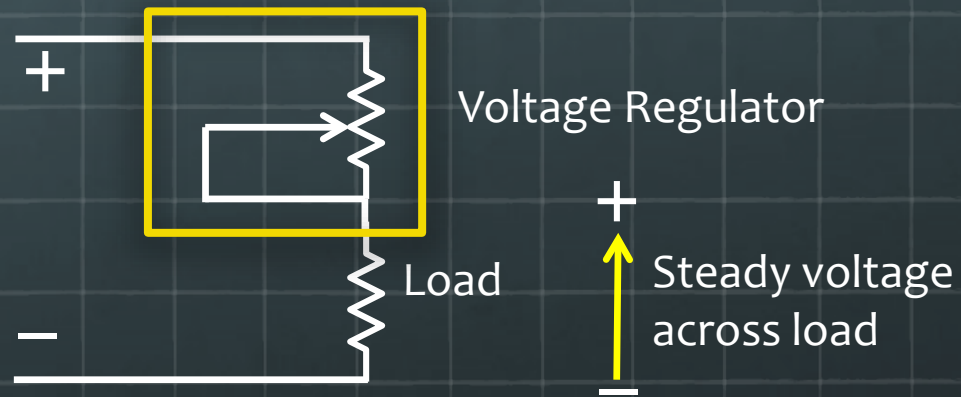

Astron Observations

- 🌐 Longevity
- 🌐 Family of RS supplies – all the same design
- 🌐 Simple and inexpensive to repair
- 🌐 No configuration control; circuit diagrams are sometimes incorrect
- 🌐 No help on Astron web site
- 🌐 Lots of help on www.repeater-builder.com
- 🌐 Electrical safety hazards

Astron RS Block Diagram

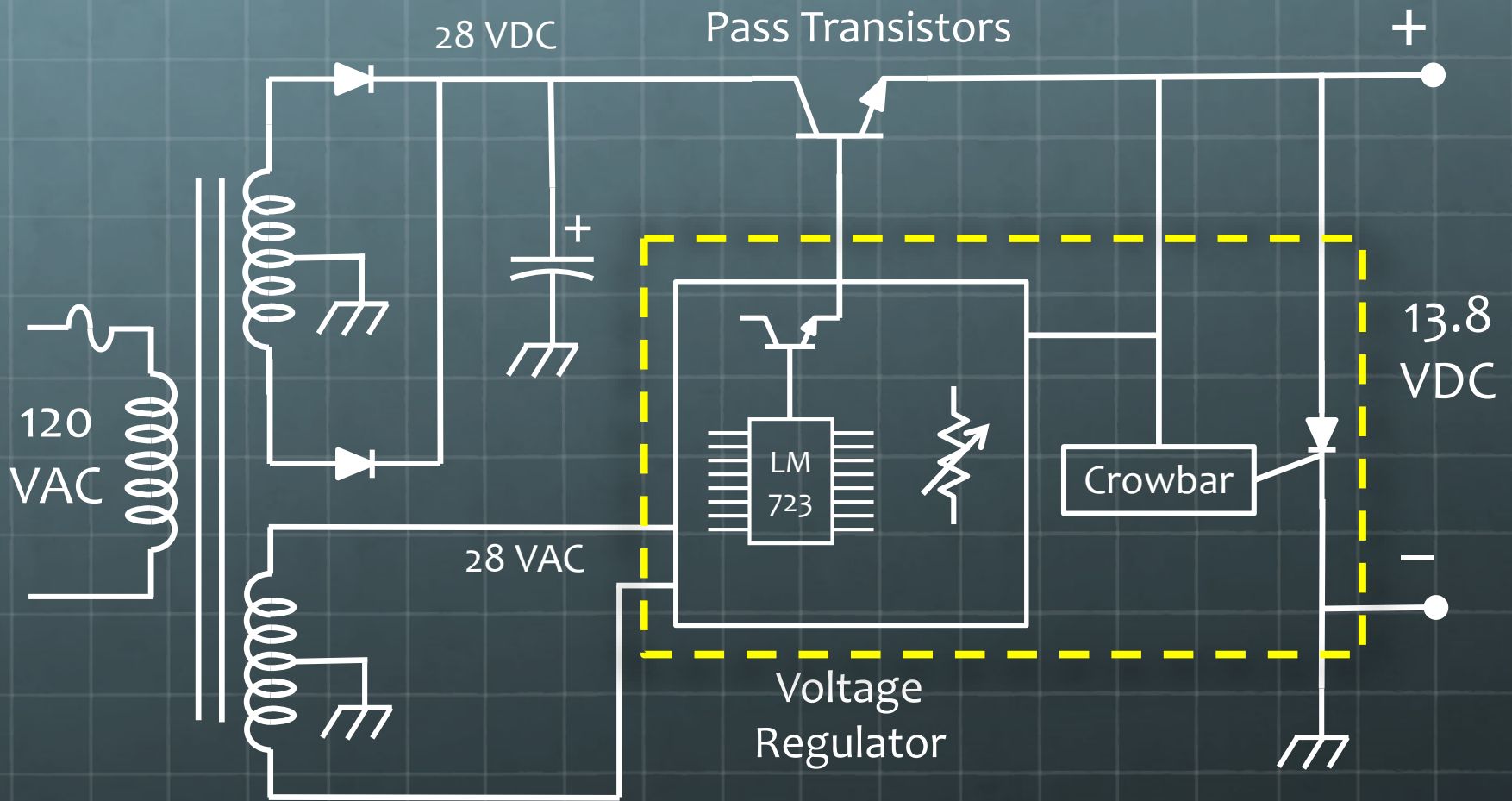

Regulator Board

Voltage Regulator

SCR*

Crowbar

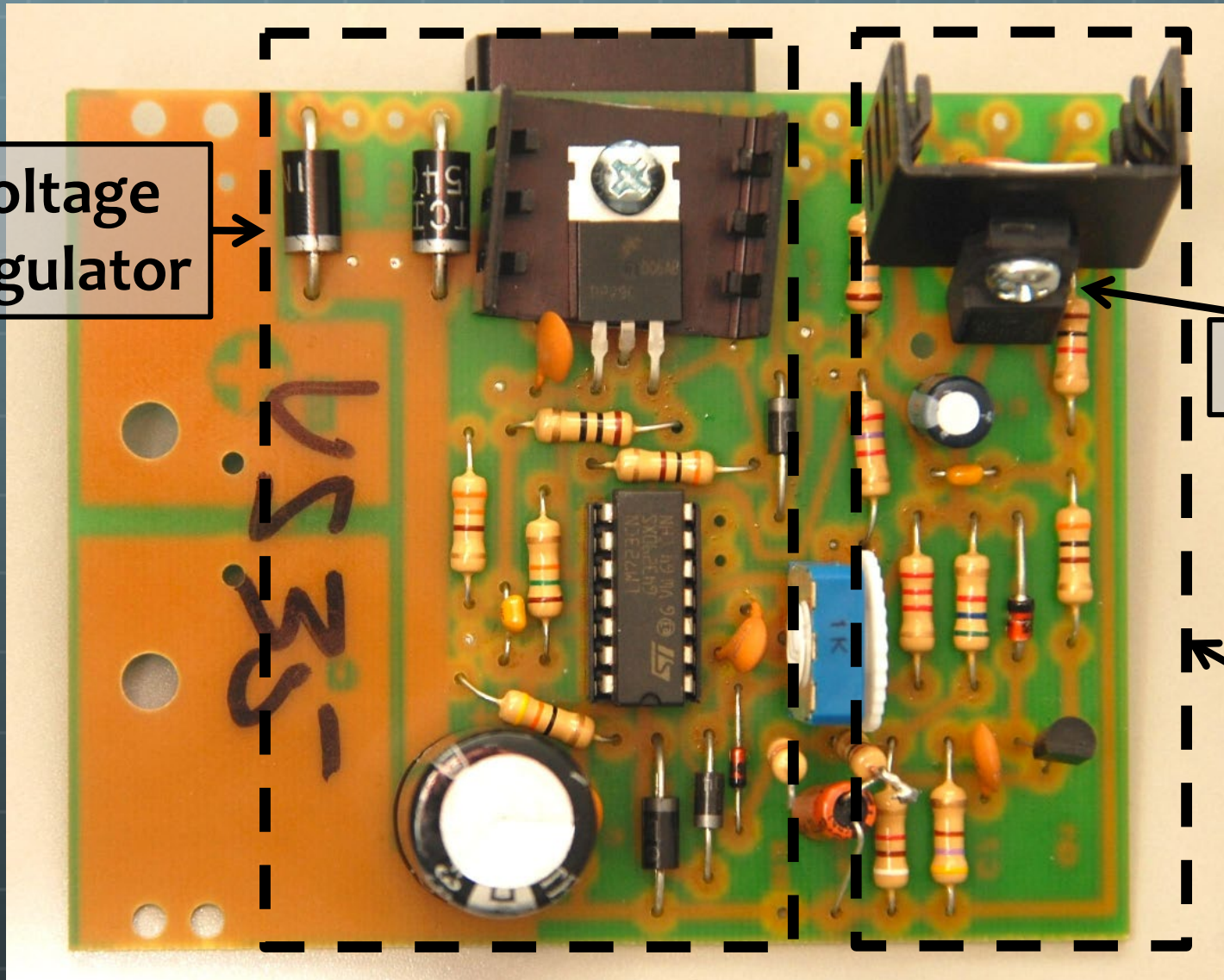

Two Diode Rectifier

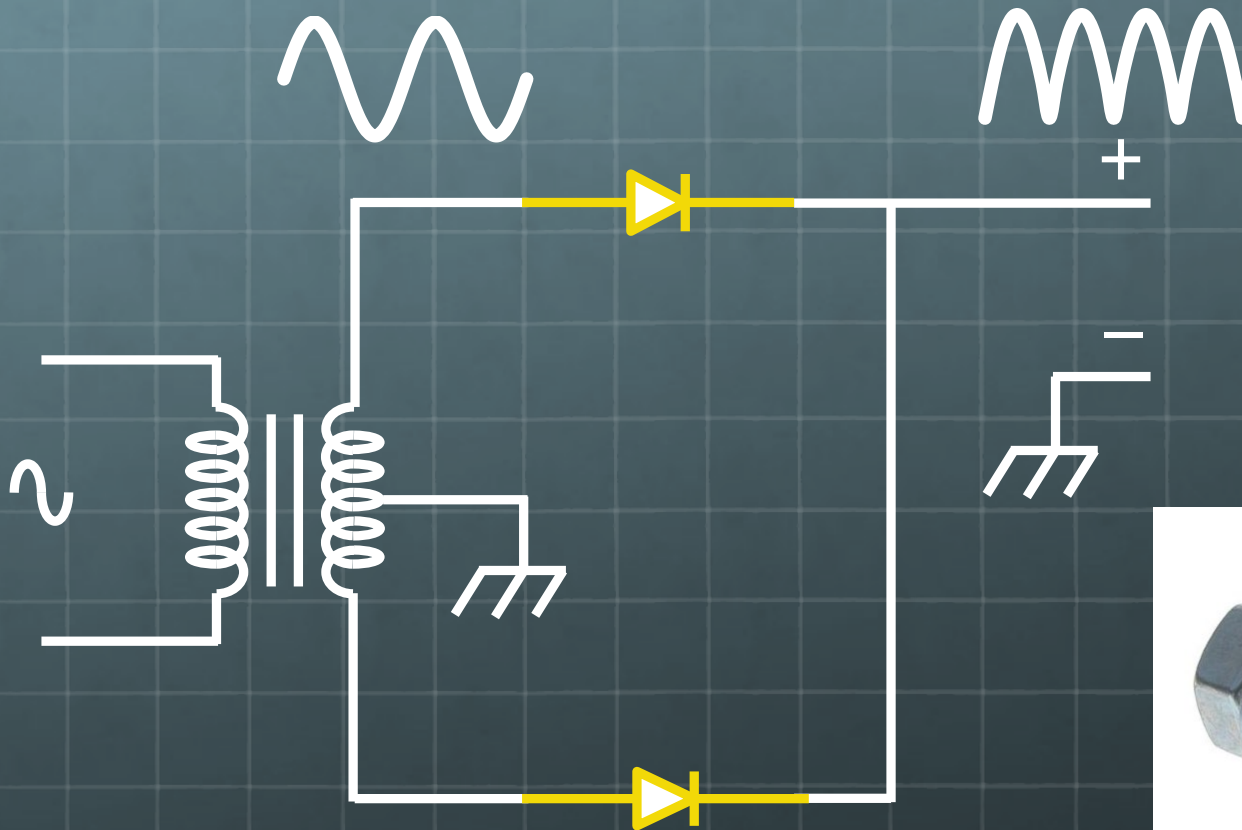

Bridge Rectifier

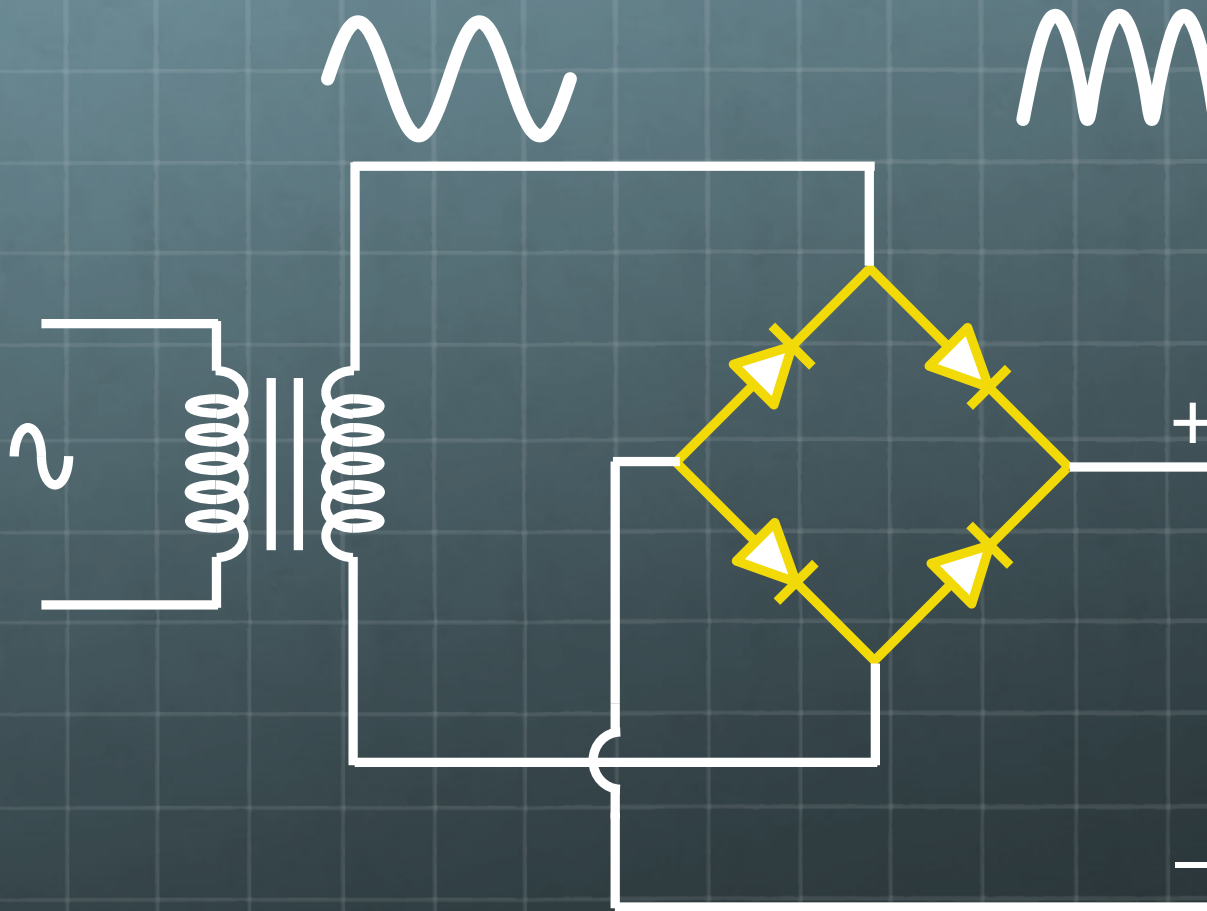

Astron Rectifier

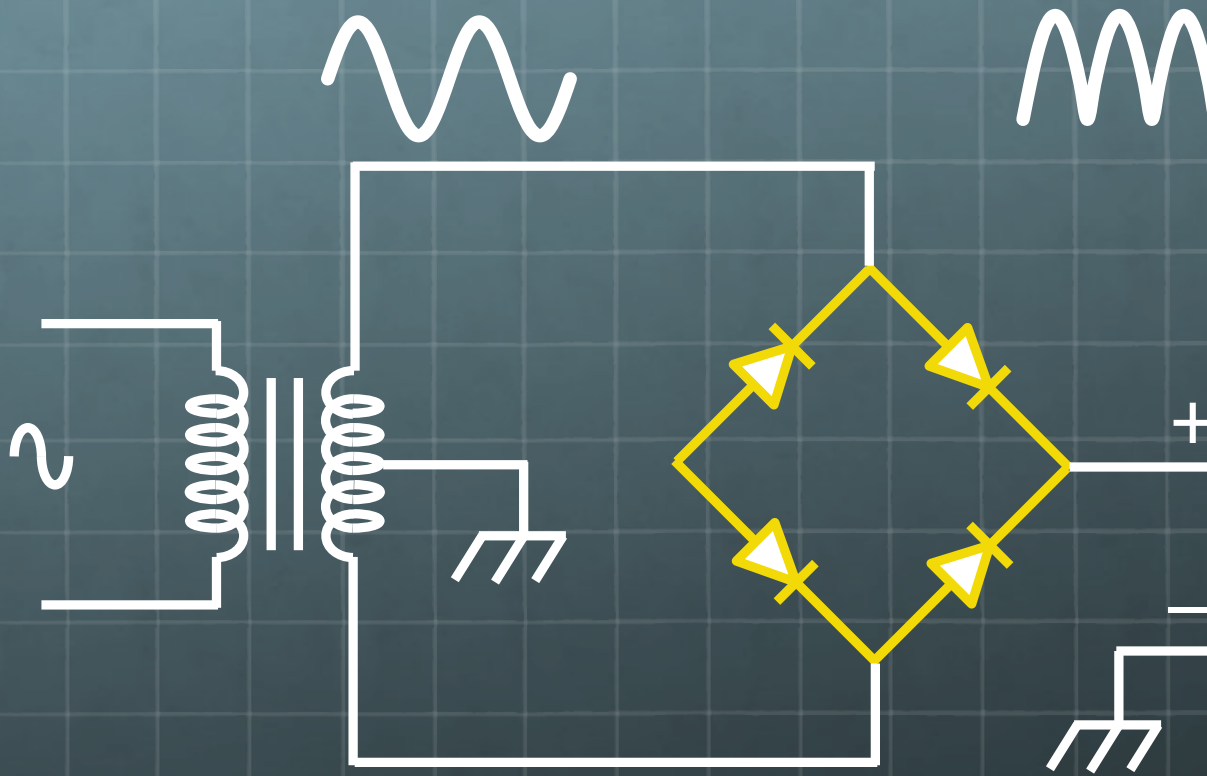

\$7.00 x 2



\$5.00

Astron RS-35 Rectifier

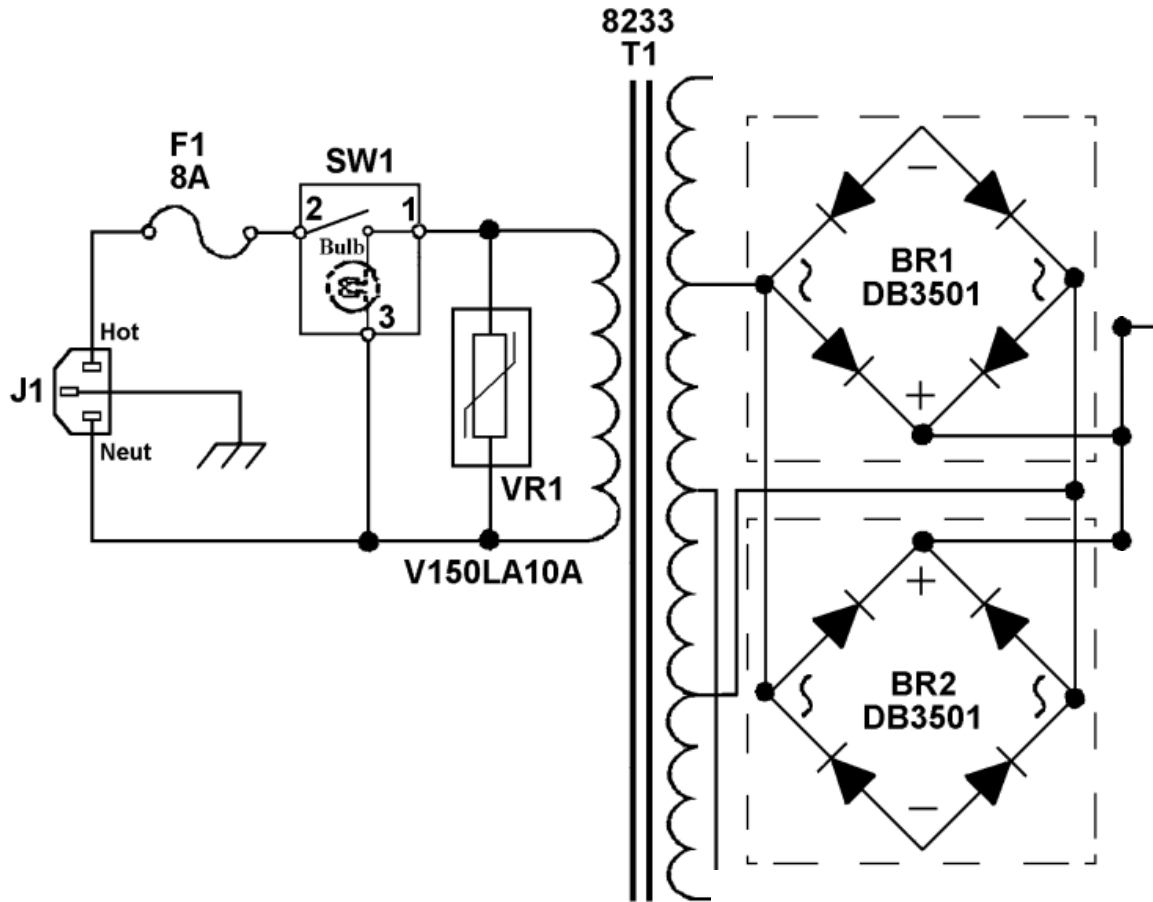

The RS-35 uses two 35 amp bridge rectifiers in parallel

Astron RS-35M

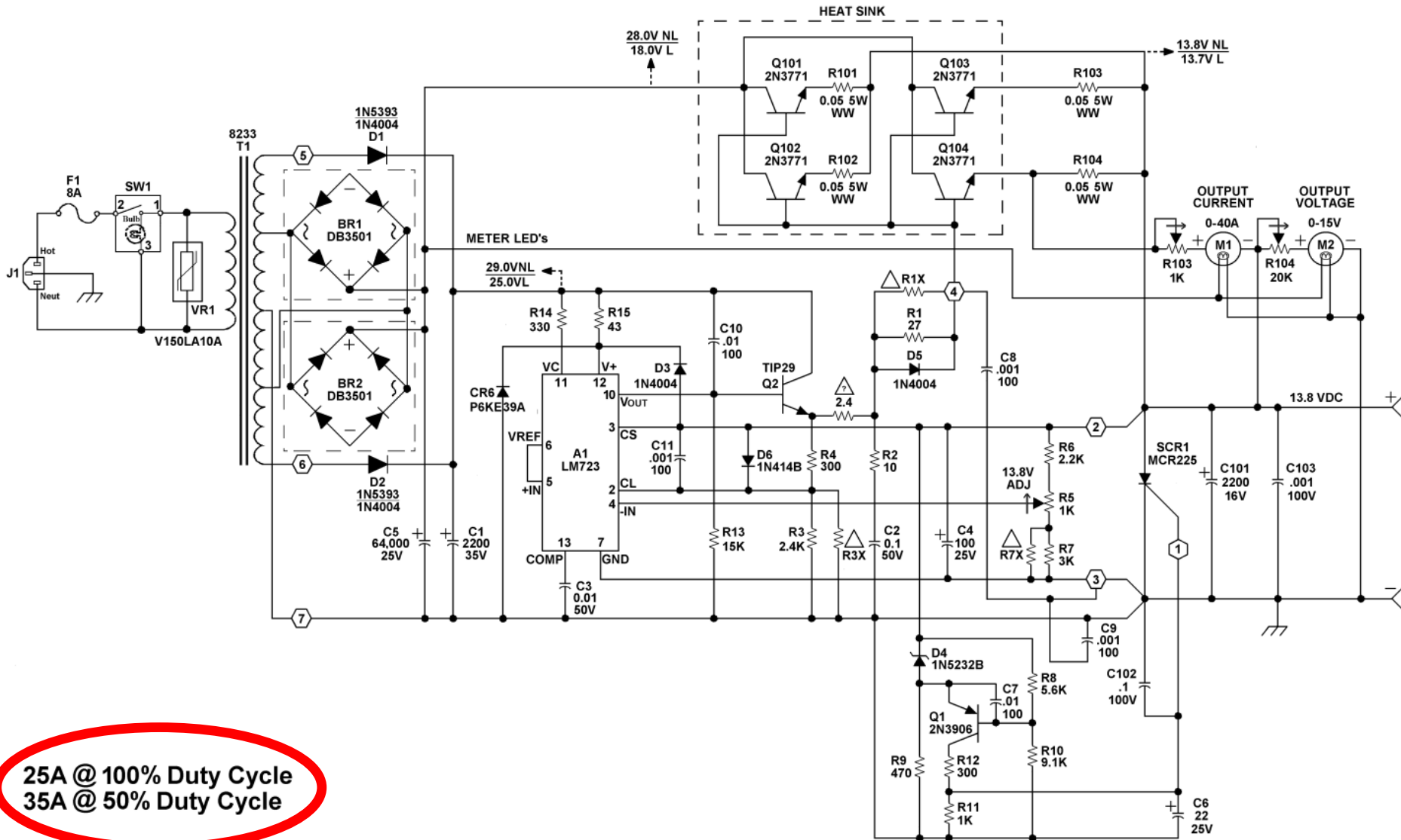

25A @ 100% Duty Cycle
35A @ 50% Duty Cycle

Electrical Safety

Exposed voltages

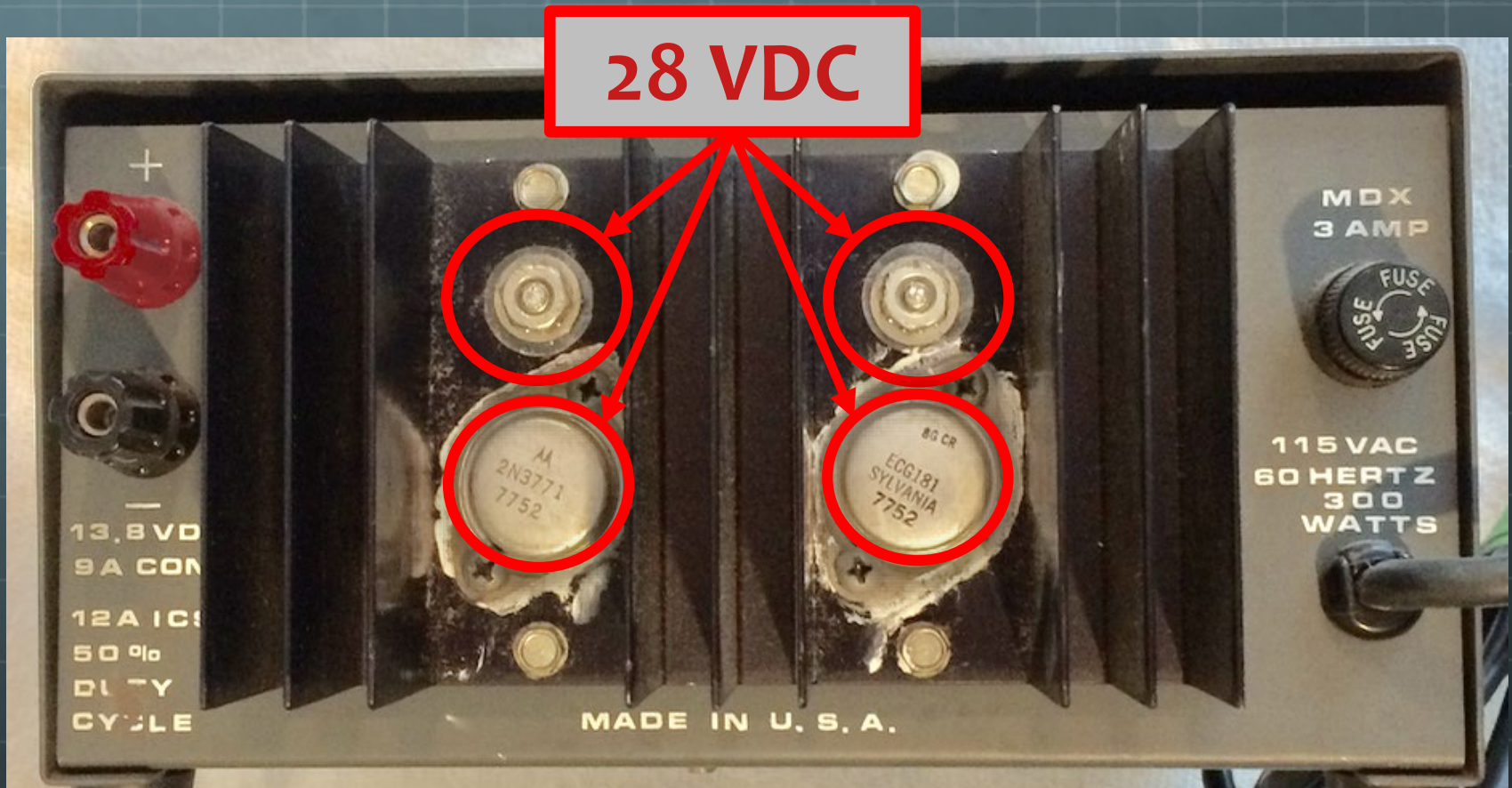

Electrical Safety

Exposed voltages

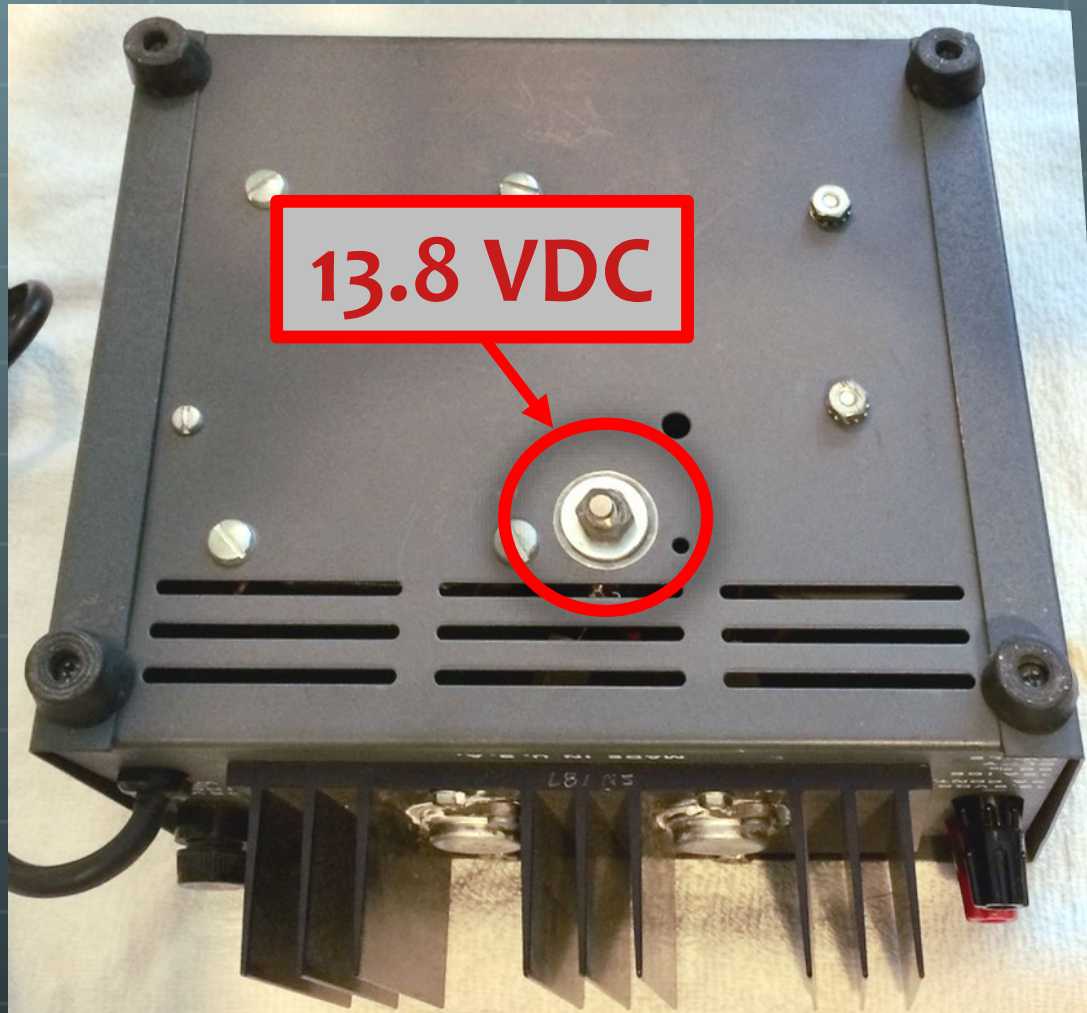

Fixes

- 🌐 Relocate diodes and SCR to the inside of the cabinet
- 🌐 Cover them up
 - 🌐 Tape
 - 🌐 Heat shrink

Floating Ground?

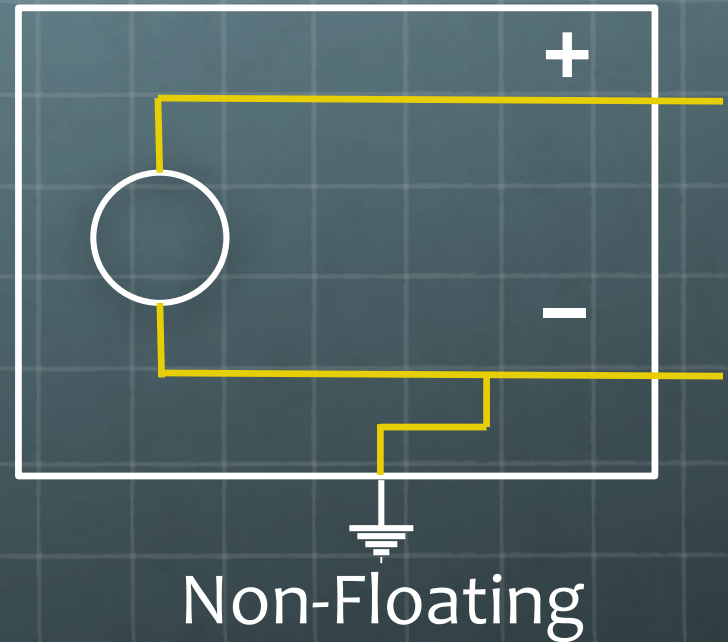
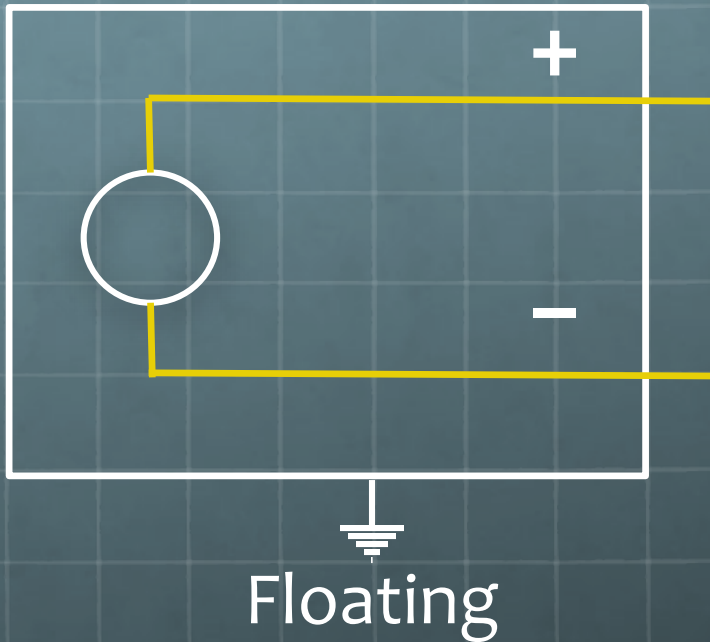

- 🌐 Astron is inconsistent – some do, and some don't
- 🌐 Don't rely on the circuit diagram; check it yourself
- 🌐 Does it matter?

Floating Ground

- 🌐 Elecraft: “We don't recommend a floating ground. If you insist on trying it, at the minimum you should fuse the + and - leads with 25 Amp fast blow fuses.”
- 🌐 Icom: “The issue is most devices that have a floating ground will short out if the negative lead touches its chassis or create a ground loop. The radio negative DC IN wire is also at the chassis (not floating) so if you tie the power supply chassis with floating ground and the radio chassis to ground you could be shorting out the power supply letting the smoke out of it and possibly the radio also.”

Don't Float

Troubleshooting

Think of the power supply as five modules

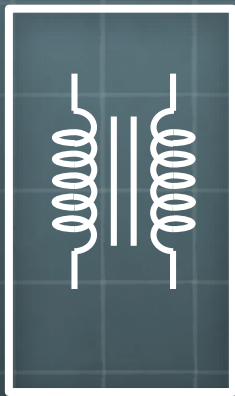

Transformer

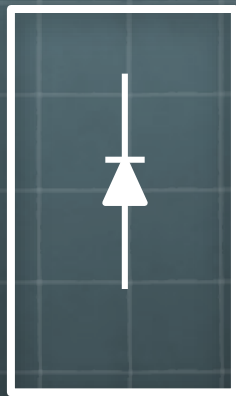

Rectifier



Filter
Capacitor



Pass
Transistors

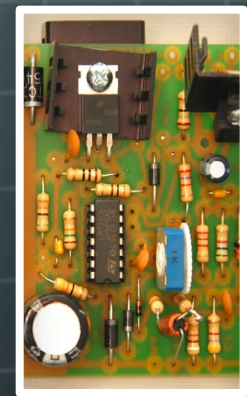

Regulator
Board

Troubleshooting

Just two symptoms

1. It blows a fuse when you turn it on
2. The output isn't what it's supposed to be

-  Too high

-  Too low

-  Drops under load

-  Hum

We'll only look at most common causes

Only a volt-ohmmeter for test equipment

Blows A Fuse

- 🌐 The most common problem in the RS-35
- 🌐 Design flaw

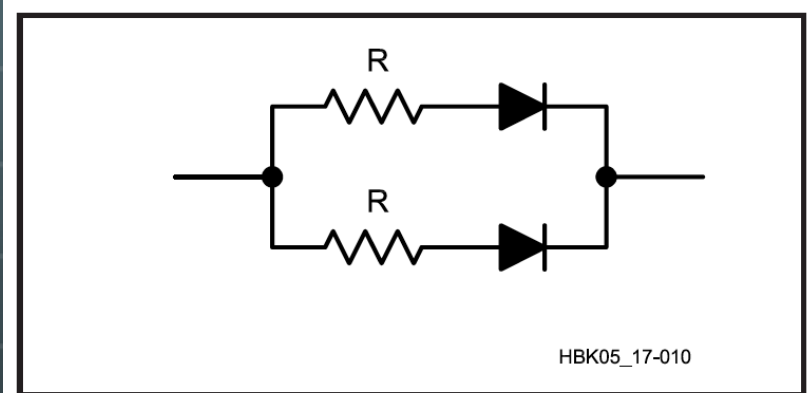
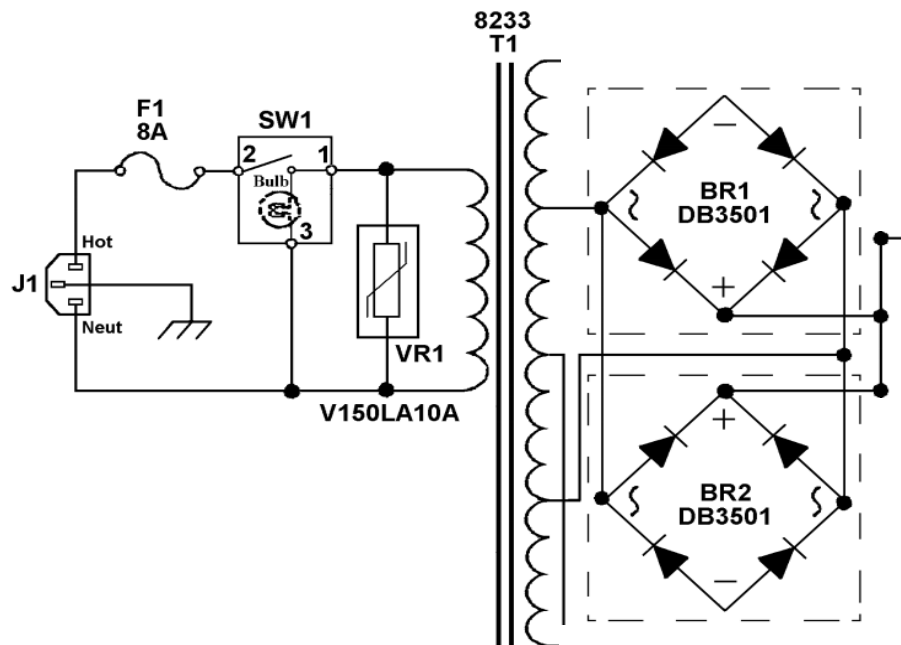
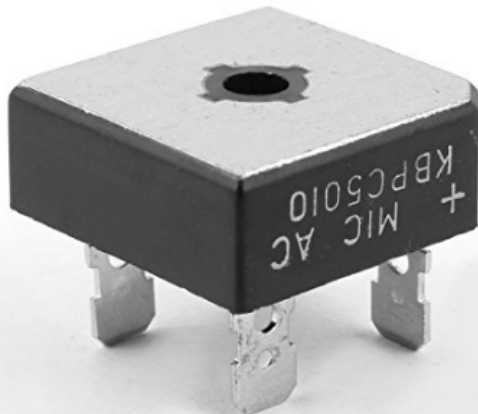
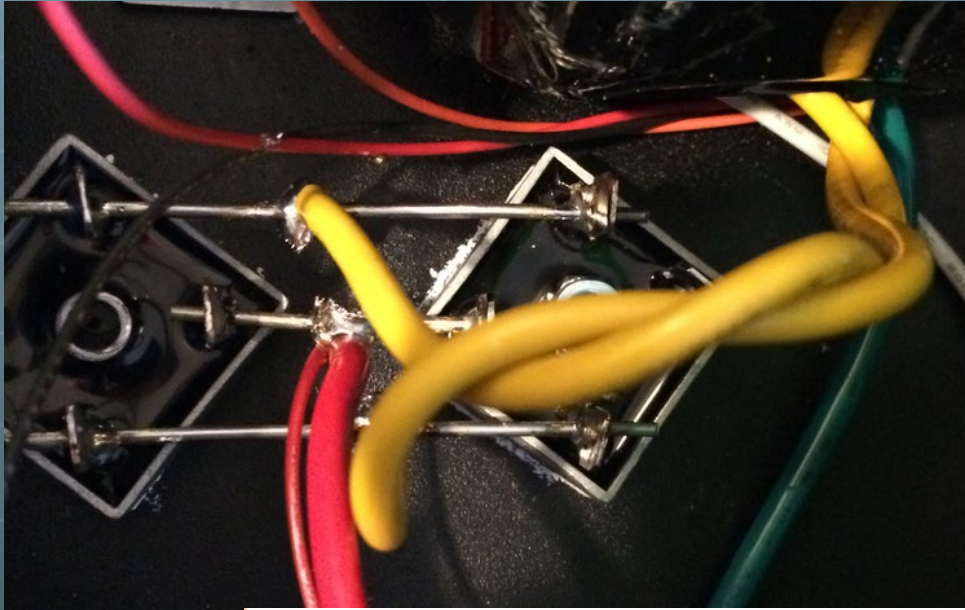

Fig 17.10 — Diodes can be connected in parallel to increase the current-handling capability of the circuit. Each diode should have a series current-equalizing resistor, with a value selected to provide a few tenths of a volt drop at the expected current.

Blows A Fuse

Troubleshooting

- 🌐 Disconnect wires
- 🌐 Test resistance
- 🌐 Replace with a single bridge rectifier



Roll over image to zoom in

uxcell Metal Case Resin KBPC5010 Single Phase Bridge Rectifier 1000V 50A

★★★★★ 16 customer reviews | 3 answered questions

Price: \$5.20 Prime

i Your cost could be \$0.20: Qualified customers get \$5 in Gift Card funds on first \$100 reload of their Amazon Gift Card Balance. [Learn more](#)

Note: Available at a lower price from [other sellers](#), potentially without free Prime shipping.

In Stock.

Want it tomorrow, Feb. 15? Order within **2 hrs 41 mins** and choose **One-Day Shipping** at checkout. [Details](#)

Sold by [uxcell](#) and [Fulfilled by Amazon](#). Gift-wrap available.

Eligible for [amazon smile](#) donation.

- Product Name : Bridge Rectifier;Model : KBPC5010;Average Forward Rectified Current : 50A
- Recurrent Peak Reverse Voltage : 1000V;Max. DC Blocking Voltage : 1000V;Terminal Size : 4.2mm;Case : 7.7mm;Case : 7.7mm

Blows A Fuse

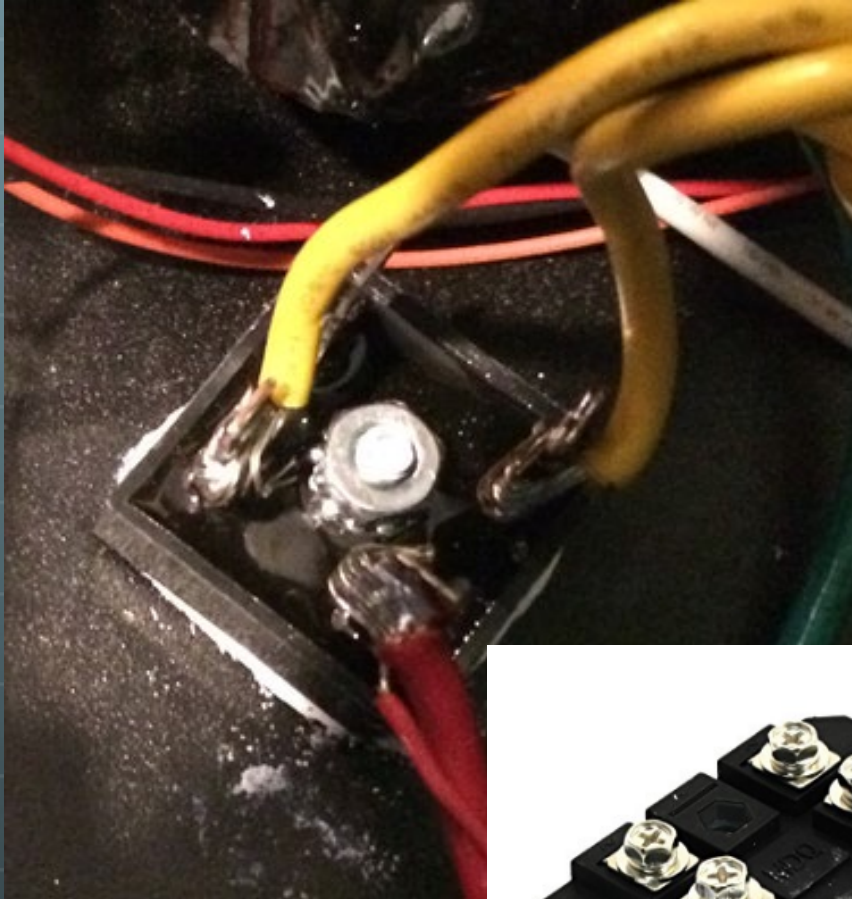

Replacing

- 🌐 Verify polarity
- 🌐 Use thermal compound



uxcell® 100A 1600V Full Wave Diode Module One Phase Bridge Rectifier MDQ-100A

★★★★★ [28 customer reviews](#) | [13 answered questions](#)

Price: **\$14.76** ✓Prime

In Stock.

Want it tomorrow, Feb. 15? Order within **2 hrs 33 mins** and choose **One-Day Shipping** at checkout. [Details](#)

Sold by [uxcell](#) and [Fulfilled by Amazon](#). Gift-wrap available.

Eligible for [amazon smile](#) donation.

- Product Name : Bridge Rectifier;Model : MDQ-100A;Max. Average Forward Rectified Current : 100A
- Repetitive Peak Reverse Voltage : 1600V;Phase : Single Phase;Terminals : 4
- Dimension : 80 x 40 x 32mm/ 3.1" x 1.6" x 1.2" (L*W*T);Mounted Hole Dia. : 6mm /

Bad Output

- **Could be:**
 - **Filter capacitor (rare)**
 - **Pass transistor(s)**
 - **Regulator board**

Pass Transistors

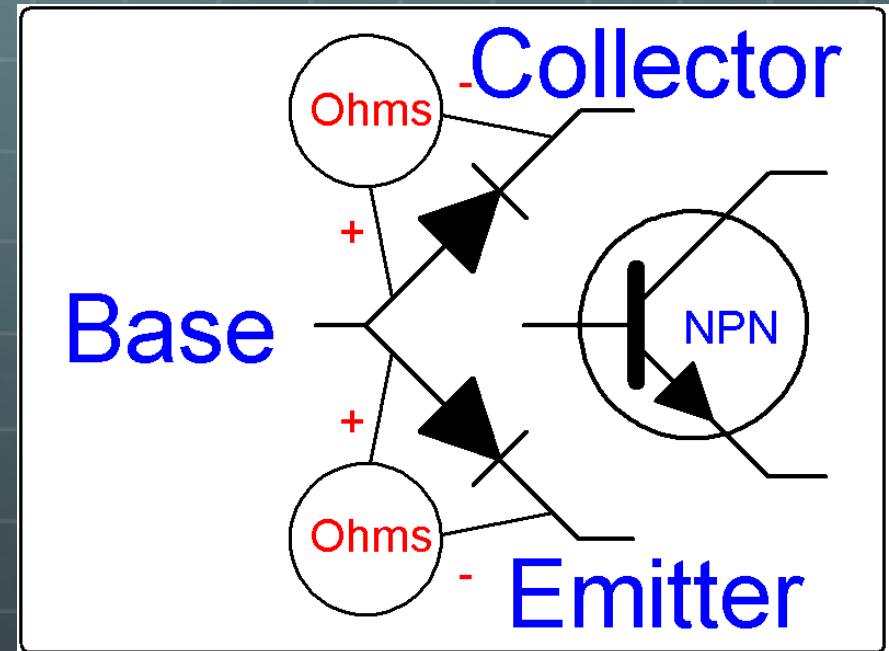

- Take off transistors and test with ohmmeter
- Positive lead of ohmmeter to base; should read $\approx 10\Omega$ across other two terminals
- Replace all if one is bad

Regulator Board

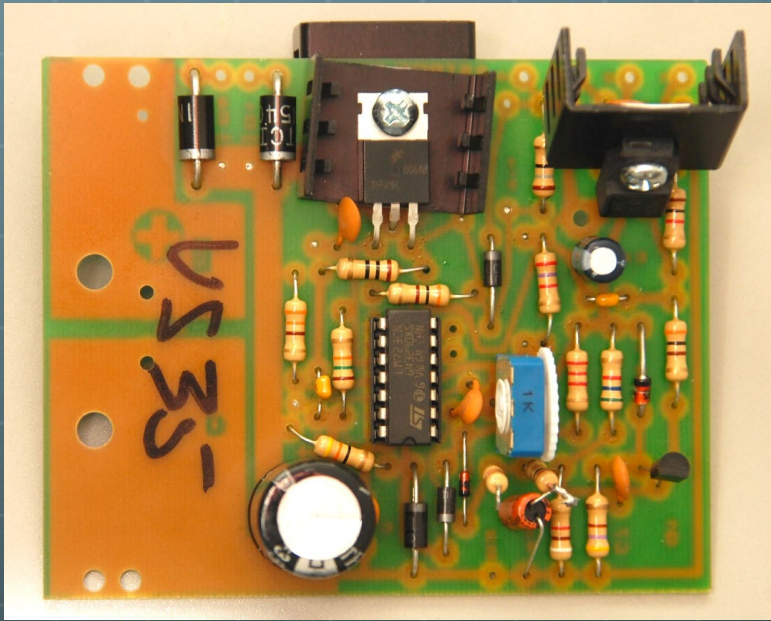

- If rectifiers, filter capacitor, and pass transistors are good, all that's left is the regulator board
- Try replacing LM723 first
- Easiest fix: call Astron and order a new board: \$20 + \$7 shipping. They will send you the latest model board.

Regulator Board Replacement

- 🌐 Label all the wires and mark the connections on the old and new boards before you remove the old board. Don't rely on the circuit diagram.
- 🌐 Take pictures before unsoldering the old board
- 🌐 Don't mess with the potentiometer
- 🌐 If your power supply has the SCR off the board, consult "Installing a New Regulator Board in an Old Astron Power Supply" on the Repeater-Builder website

Test and Calibration

- 🌐 The Prime Directive: *Do not use your transceiver as a dummy load!*
- 🌐 Dummy load can be auto headlight (caution) or resistor load bank.

🌐 Turn on power
output voltage
voltage potentiometer

🌐 Run power supply
or less. Check



measure
and output

at one amp
elements.

**Warning:
temperatures**

QST Feb 2017

**check
ply first!**

Test and Calibration

- 🌐 Run power supply at increased loads for a few minutes.
- 🌐 Check for hot/cold components at each load increment
- 🌐 Check voltage stability
- 🌐 Check power supply voltmeter and ammeter calibrations. Adjust with plastic tool.
- 🌐 **GET ON THE AIR!**

Power Supply Efficiency



$$\text{Efficiency} = \frac{\text{Output Power}}{\text{Input Power}} \times 100\%$$



We can compare efficiency of the linear versus switched-mode power supplies

Power Supply Efficiency

Astron			
Watts In	Watts Out	Efficiency	Loss (Watts)
29	0	0%	29
51	13	25%	38
83	34	41%	49
109	55	50%	55
187	98	52%	89
271	150	55%	121
348	198	57%	150
486	285	59%	201

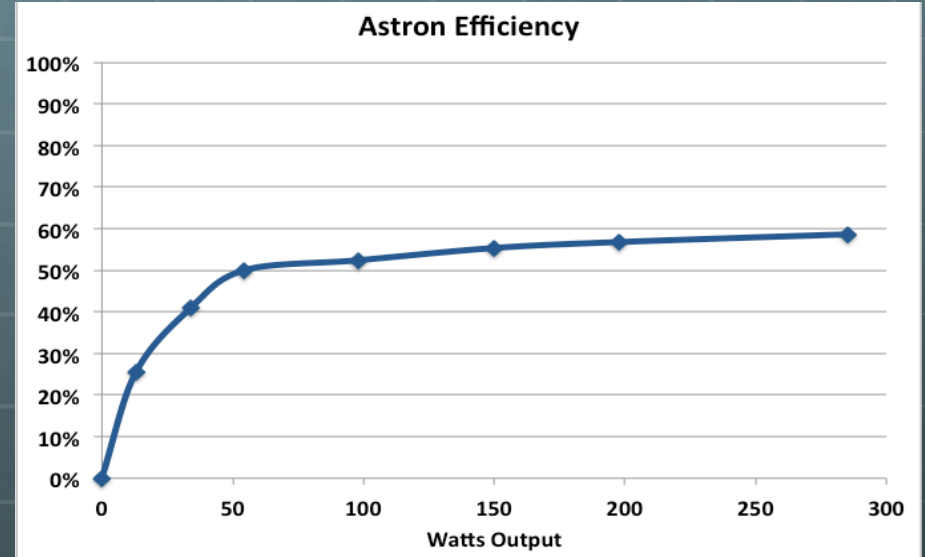

PowerWerx			
Watts In	Watts Out	Efficiency	Loss (Watts)
12	0	0%	12
29	12	43%	17
50	32	65%	18
68	48	71%	20
128	97	76%	31
186	143	77%	43
239	186	78%	53
354	276	78%	78

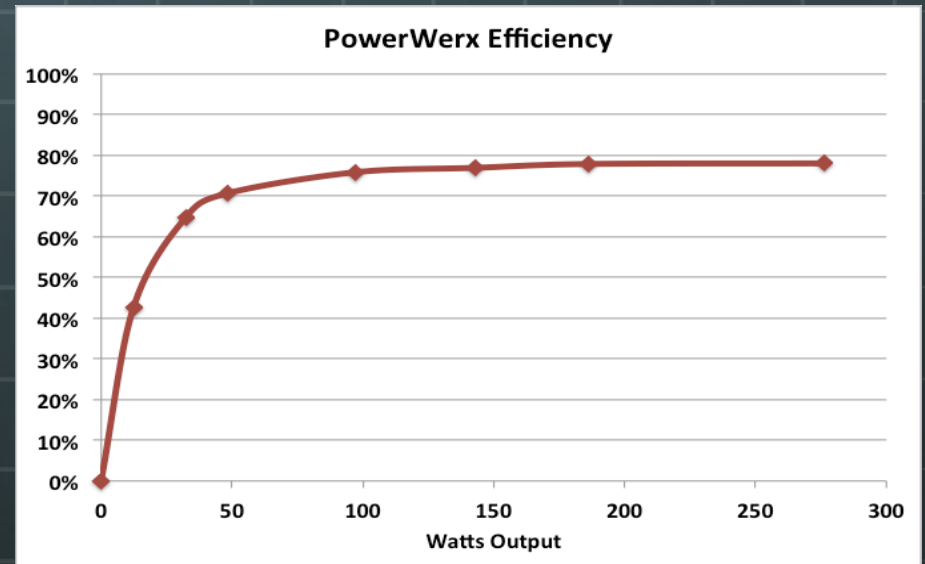

QST Product Review

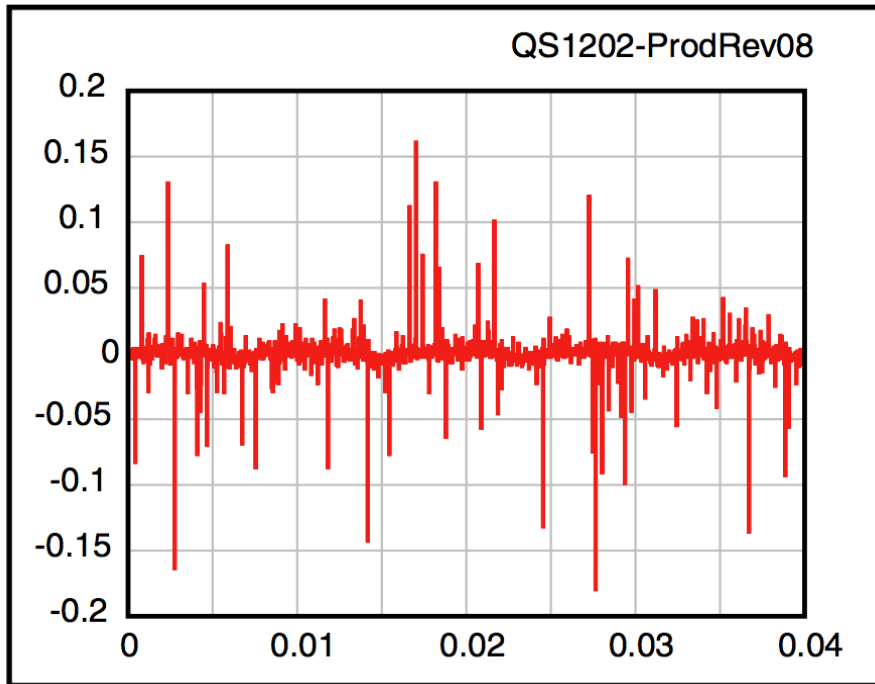

Figure 8 — An oscilloscope trace of the dc output of the Powerwerx SS-30DV under 20 A load. The vertical scale is 50 mV/div and the horizontal scale is 5 ms/div. The level of the dc ripple is approximately 30 mV p-p. Spikes due to switching measure about 350 mV p-p.

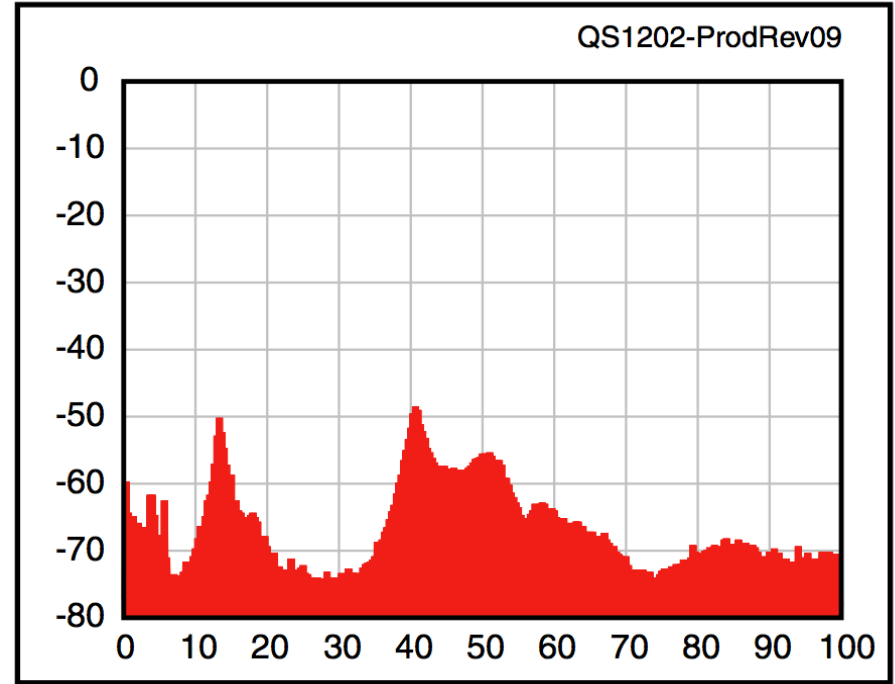
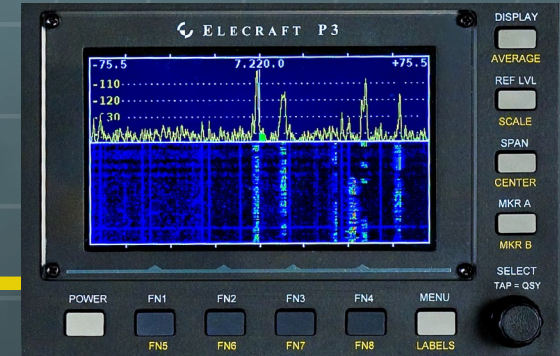

Figure 9 — Spectral plot (0-100 MHz) of the output of the Powerwerx SS-30DV under 20 A load. The reference level is 0 dBm and the vertical scale is 10 dB/div.

Noise Measurements



Switching PS Noise

